

## Main Components

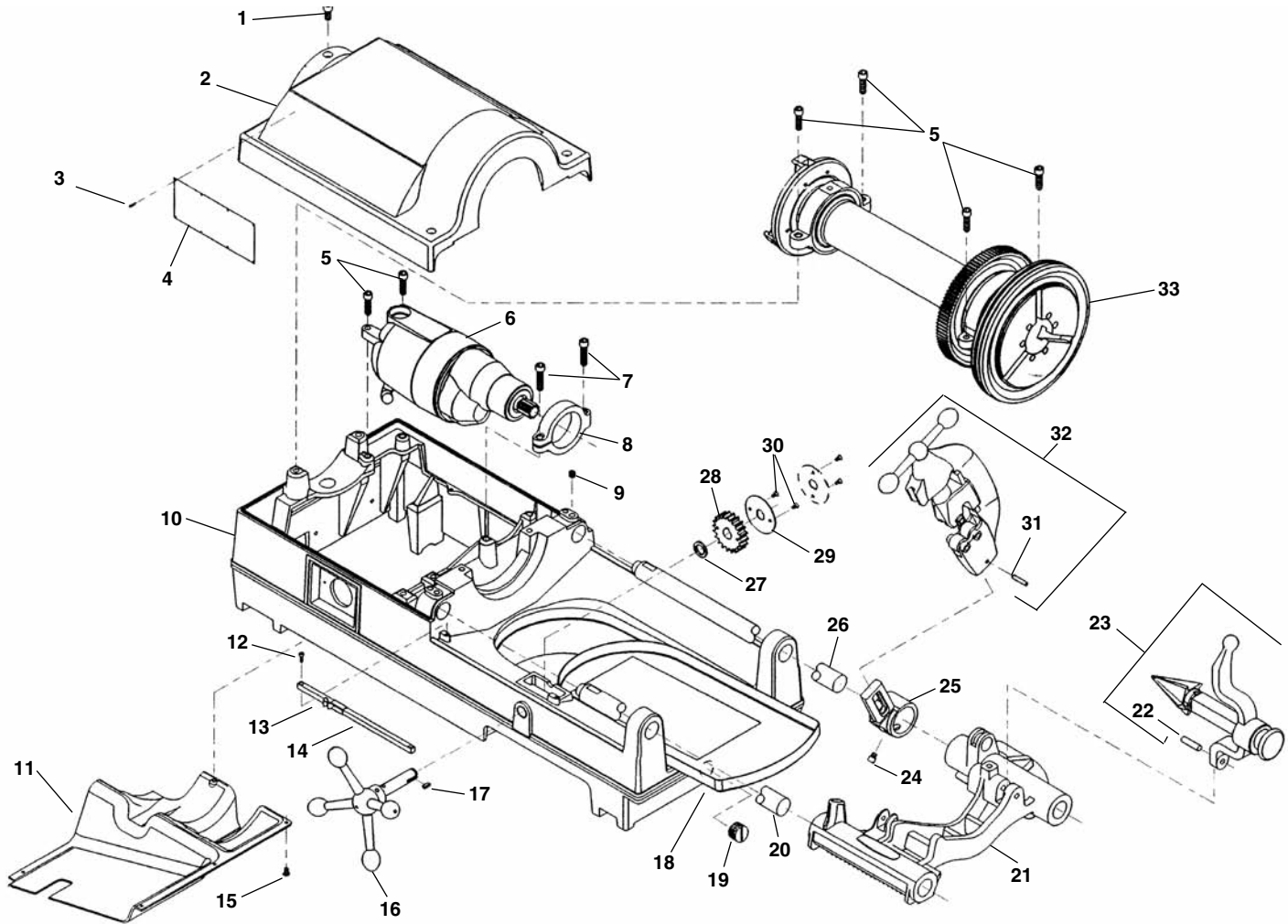

**NOTE: Order parts by Catalog Number only.  
DO NOT order by Reference Number.**

Ref. No.	Catalog No.	Description	Ref. No.	Catalog No.	Description
1	46760	Screw (3)	17	46930	Key $\frac{3}{16}$ " Sq. x $\frac{1}{2}$ "
2	62062	Top Cover	18	43355	Chip Tray
3	85920	Pop Rivet (8)	19	48337	Drain Plug
4	88690	Warning Plate	20	45440	Front Support Bar
5	46745	Screw	21	62057	Carriage Assembly
6	64447	1194 Motor, 115V, 36 RPM	22	47065	Hinge Pin
—	64452	1194 A Motor, 115V, 54 RPM	23	42365	341 Reamer Assembly
—	64457	2394 Motor, 230V, 36 RPM	24	44930	Stop Screw
7	44220	Screw (2)	25	43690	Cutter Arm
8	43795	Motor Bracket	26	45220	Rear Support Bar
9	46800	Set Screw (2)	27	47145	Spacer
10	61952	Base	28	45430	Pinion Gear
11	61947	Bottom Cover	29	47120	Lock Plate
12	45615	Screw (2)	30	46785	Screw 10 - 32 x $\frac{3}{8}$ " (2)
13	47110	Indicator Slide	31	47135	Stop Pin
14	47105	Indicator Bar	32	42390	820 Cutter Assembly
15	45420	Screw (5)	33	47585	Drive Shaft Assembly
16	46510	Handwheel			